



Installation Guide

Setting Out	page 2
Excavation	page 3
Water level	page 4
Sand bed/crushed rock	page 5
Site	page 6
Using a crane	page 8
Installation	page 9
Drainage	page 10
Plumbing	page 12
Filtration	page 13
Filter set up	page 14
Venturi spa jets	page 15
Skimmer box	page 16
Concrete bond beam	page 17
Waterfalls	page 18
Light installation	page 19

Setting Out

Before you start digging and filling we will explain the set out and the preparation of your pool and site and how to obtain the correct levels.

N.B.: Read local laws requirements carefully and note that each locality may vary several inspections may be required.

Firstly, decide where you want your pool. Lay out the template, which we can supply (at a nominal cost) and check that it is, in the right place. Mark the perimeter of the template with marker paint or sprinkling a generous amount of lime around the edge, this is so you know where to dig. If you are on a sloping site we recommend a "cut and fill". Do this before marking the exact location of the template to ensure your excavation is accurate.

Hammer two pegs outside the excavation for the shallow and deep-ends. The reason for using the pegs is that when you are digging the hole you will know exactly

where the deepest and shallowest points are. The pegs also act as "datum" points. It is essential that your pool is at least 8" above ground level on a flat site and at least 6" out of ground on a sloping site.

(This ensures you have no ground water problems. If the ground water outside the pool is higher than the water inside the pool, it will float just like a boat).

You can also use a fixed course of bricks on your house for the datum point. Constantly refer to datum pegs to ensure dig depths are correct and that your pool is level when backfilling.

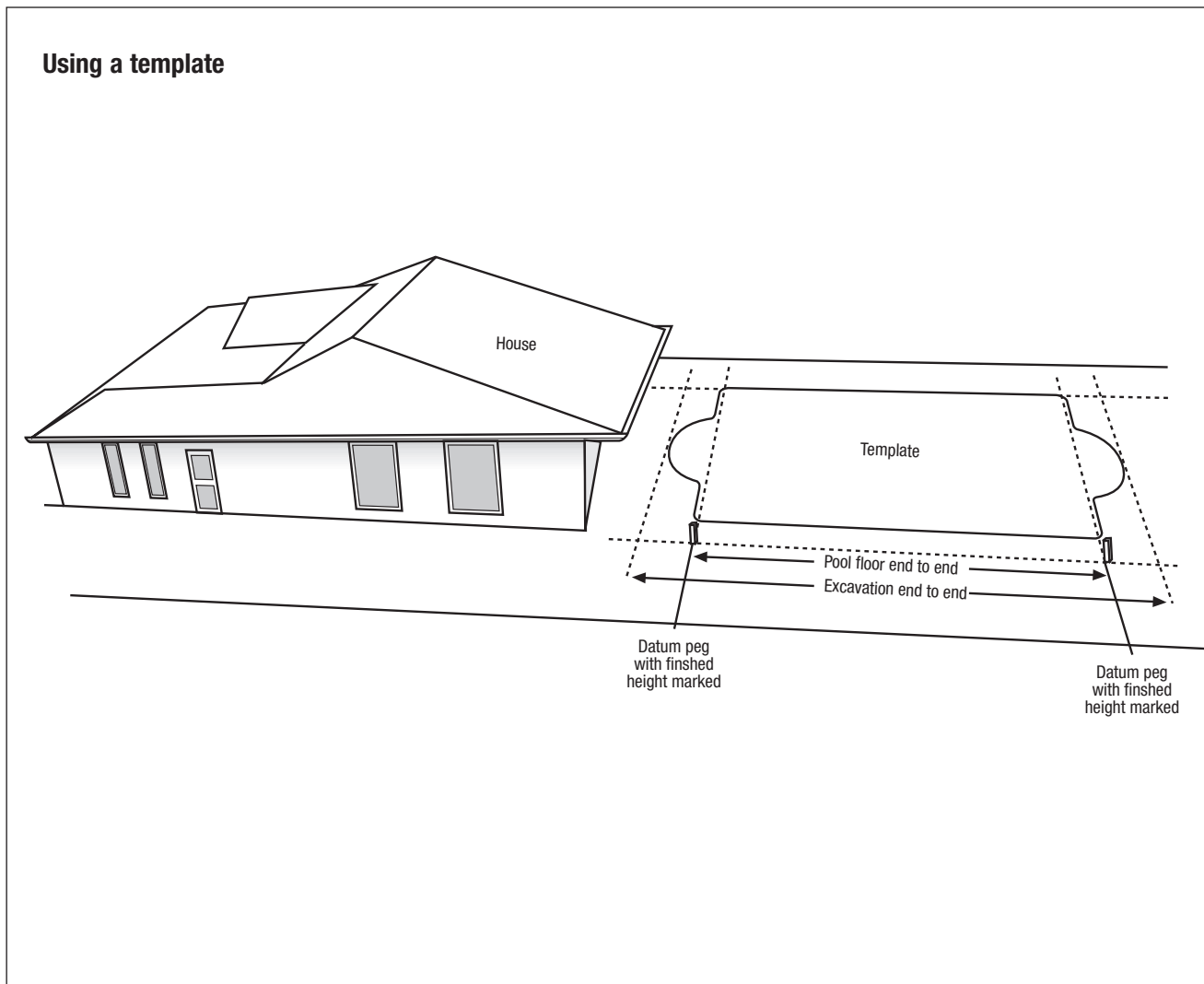

Excavation

Now start digging your pool to the correct shape and size. Use your installation sheet to obtain the correct levels. Remember not to over excavate around the step and ledge area otherwise excess backfill will be needed. Check dig depths often during excavation to ensure the right levels are achieved. It is important and most crucial that the distance between these two dig depths is correct so that the pool coping sits level upon installation. *(Refer to your dig sheet for your pools measurements).*

When referring to the pool finished heights, they are to the top of the pool shell coping. The pool template is measured to the outside edge of the pool coping. Lime is sprinkled to approximately 2" past the template and as Barrier Reef Pools have a gentle wall slope, your excavation should reflect this with a 9 degree wall slope. Digging your vertical walls will increase the quantity of backfill required dramatically.

If it is not possible to pre-plumb solar suction/ returns or spa manifold pipes, ensure you dig an access area to do this once the pool is in the ground.

It is a good idea to have the excavator dig the trench from the pool to the filter for the pipe work, particularly on a Manhattan. A separate trench from the spa to the filter to accommodate the excessive pipes is essential.

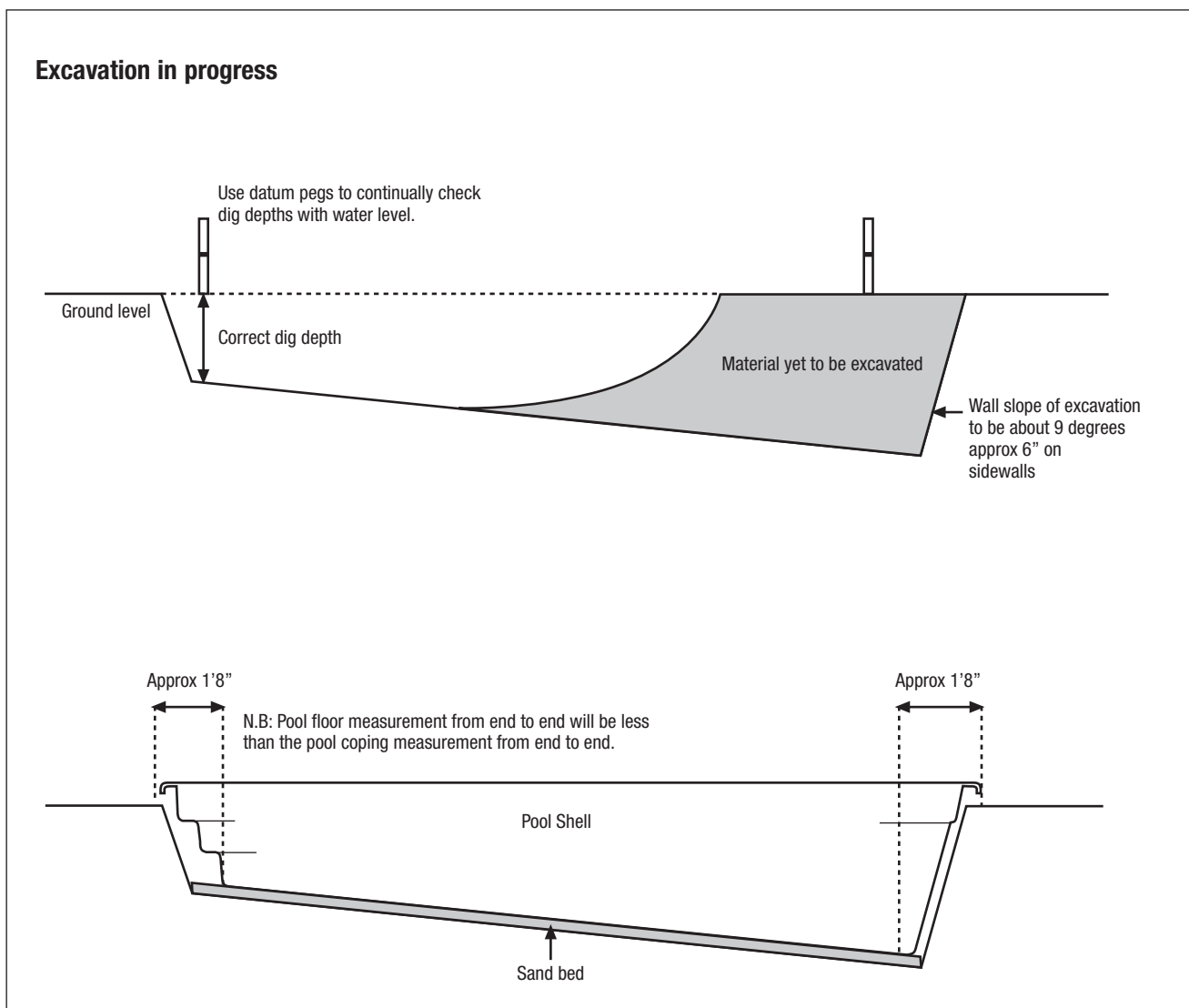

Water Level

Before you start digging it is a good idea to make a water level. This measuring tool is easily made and can be used to check all your levels and dig depths with great accuracy.

1) Length of clear hose up to 49'3" - smaller diameter hose is best 0.25"-0.3"

2) Clear plastic container such as an empty 1/2 cis gallon bottle of soft drink or a 4 gallon chlorine screw top container. 3/4 filled with water is less likely to be knocked over.

3) Colored food dye.

Connect one end of the clear hose to the plastic container (usually by drilling a hole in the lid of the container to neatly fit the hose) and push hose inside the container until it reaches the bottom. Also drill same size hole beside hose as a breather hole.

Add some colored food dye to the container (*to make the water level easier to see*) and then fill the container with water.

Tilt the container to allow water to siphon through the clear hose so that there are no air traps from the container to the end of the hose.

Set the container next to the datum point so that the water level in the container is at the same height as the fixed datum.

You will now notice that where ever you take the clear hose, the water level near the end of the hose will always be at the same height as the water level in the container.

Alternately you can use a dumpy or laser level - all of which will give you the same result.

A length of PVC pipe or timber will also come in handy. Mark the pipe with the correct dig depths and use it in conjunction with the water level to check your dig depths during excavation.

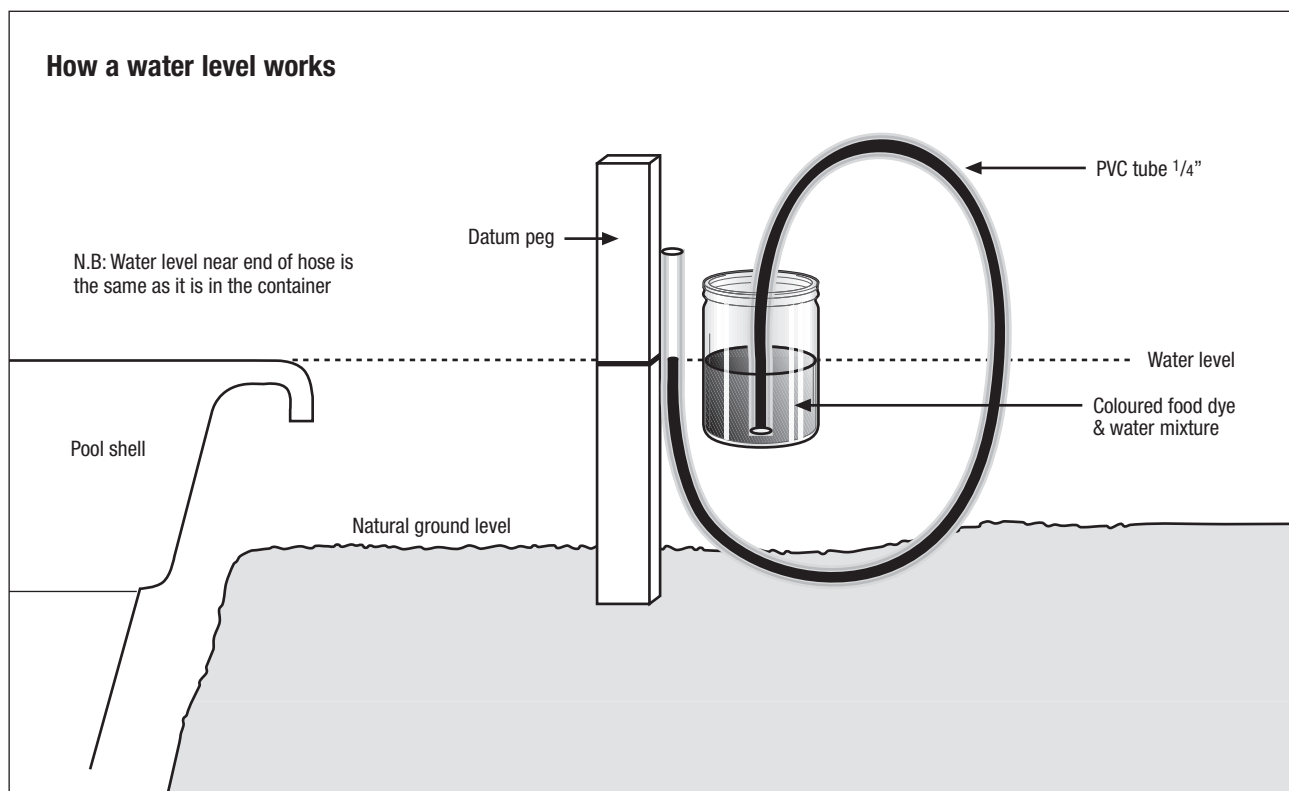

Sand Bed/Crushed Rock

Now that excavation is complete and the levels are correct it is time to do the sand bed. If you have dug the hole too deep, the sand bed may be used to get the correct depths. It is essential that your sand bed is at the correct level and has the correct slope from shallow to deep end, as this is what the pool will sit on it will determine the finished level of the pool coping.

Hammer in 4 pins, one at each corner of the floor taking measurements of actual floor length from each dig plan. Mark on each pin the top of the sand bed. Use a string line to join all the pins at these marks and screed off material to the string line.

Use 1" X 1" square steel screed rails if required to help support string line.

Pins should be approximately 9'3" apart across width of pool. Remove pins, string line and rails and fill voids left by the rails.

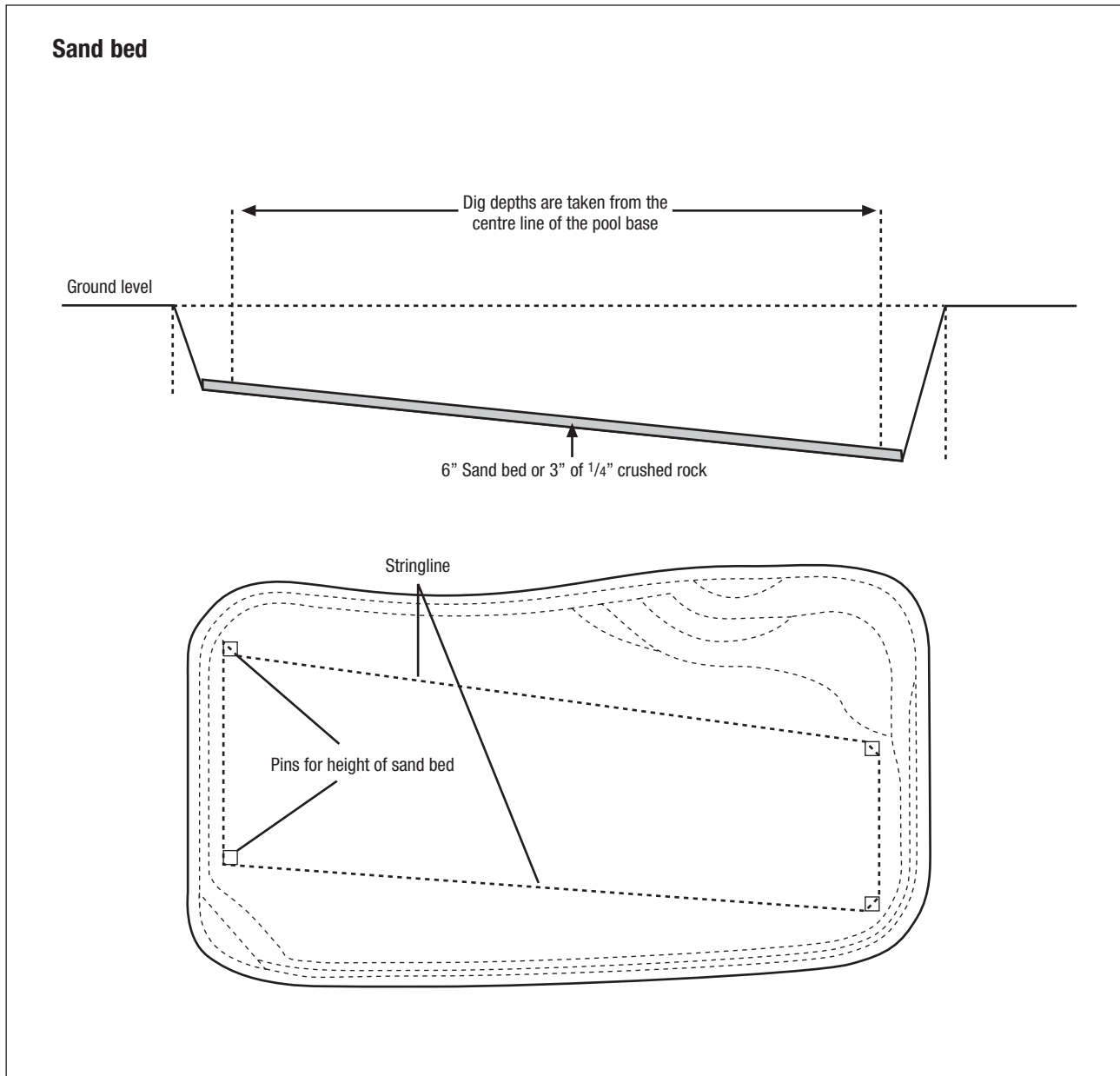

Level site

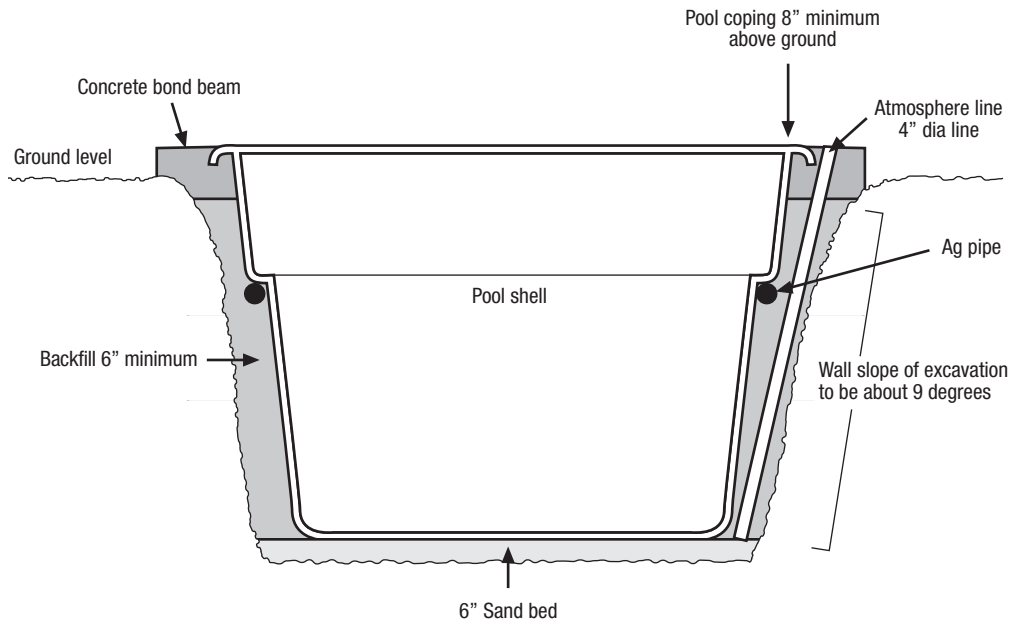

Sloping site

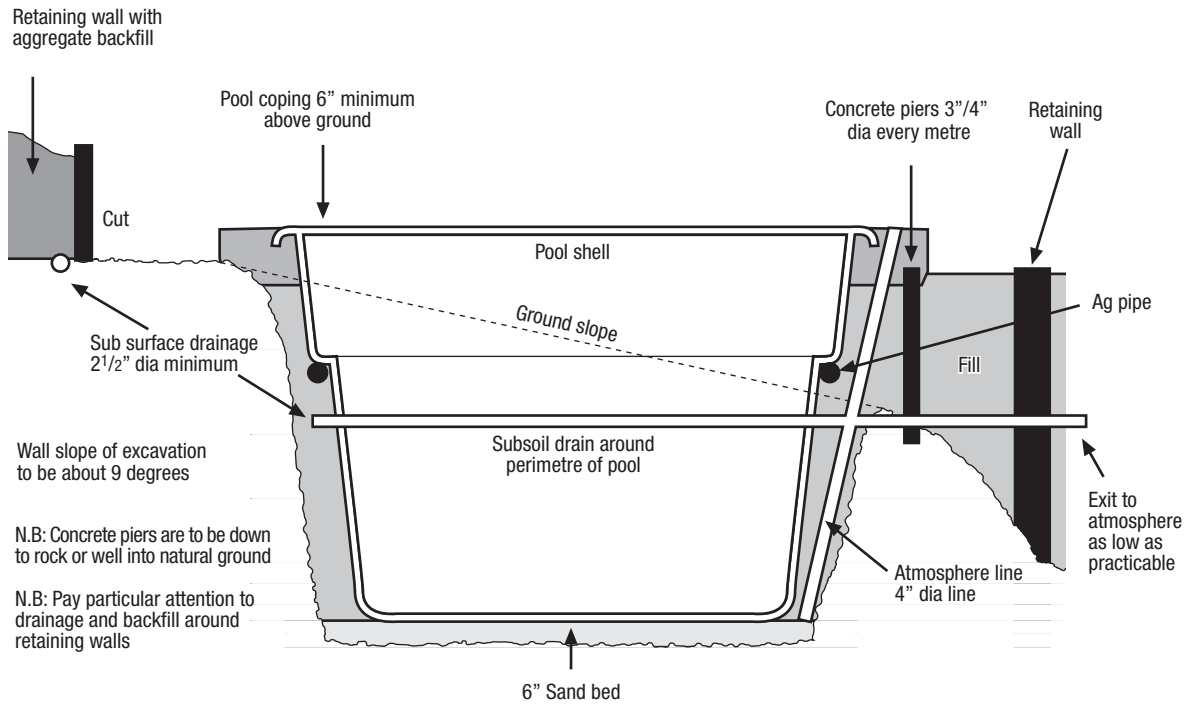

Site

You are now ready to place the pool in the excavation. You can do this by:

Using a crane, your crane operator must use a spreader bar when lifting your pool. If a spreader bar is not used when lifting your pool, it may be damaged.

N.B. You must allow enough access for our truck. The truck must be able to turn into your drive or access area. Telegraph poles, letter boxes and trees cause us a lot of problems as they often get in the way of trucks turning circle.

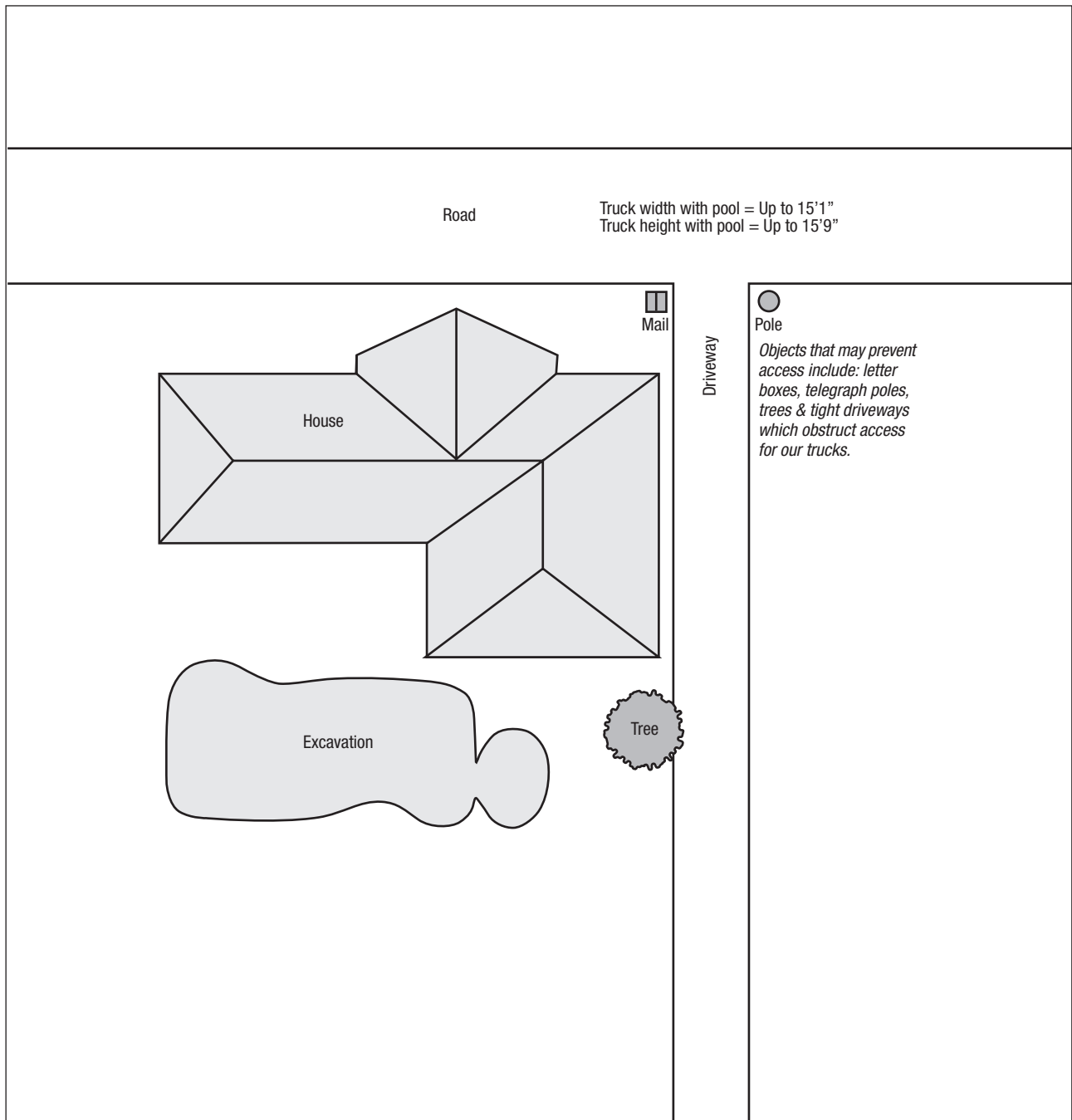

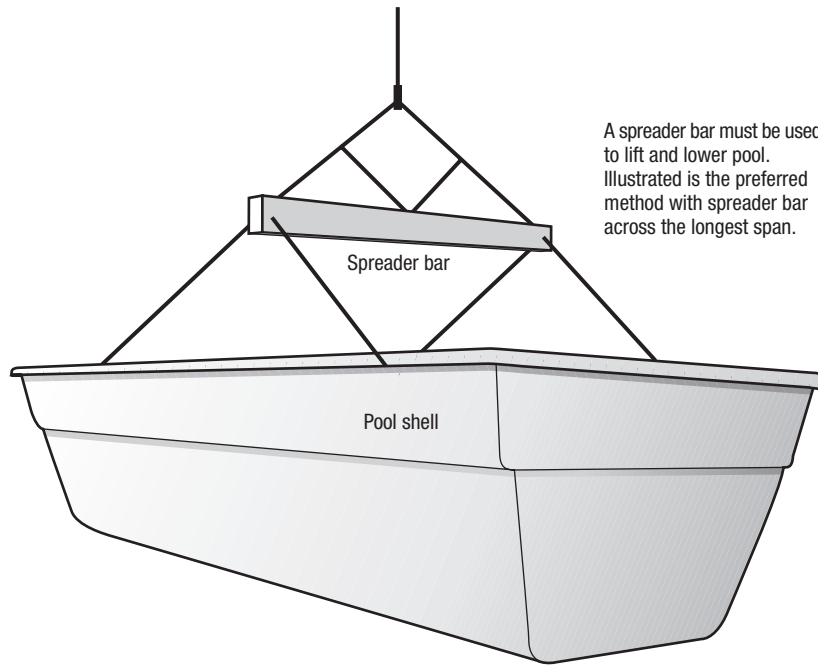

A spreader bar must be used to lift and lower pool. Illustrated is the preferred method with spreader bar across the longest span.

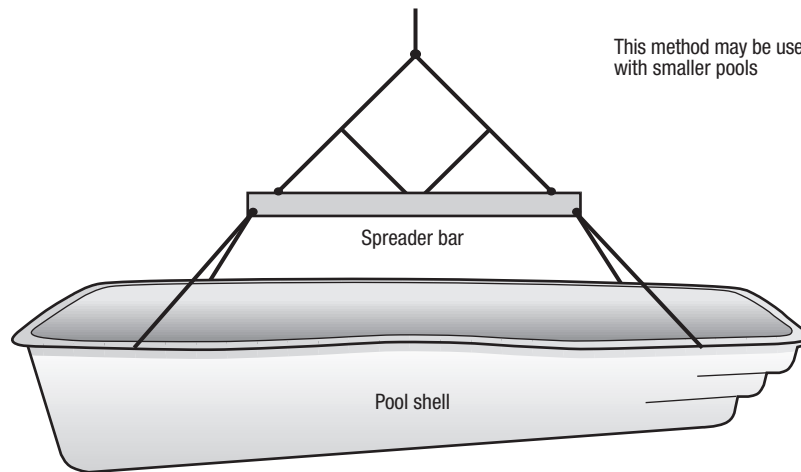

This method may be used with smaller pools

Installation

If the pool is not level to your satisfaction it may be adjusted in the following manner:

Once the pool has been placed in the excavation check it for level in relation to datum. If it is too high you may have to remove it and rescreen the sand bed. Once it is close you may dismiss the crane and level the pool. Using a steel bar, lift the low corners of the pool and backfill into the void created. Using a garden hose with a short length of 1" PVC pipe on the end. Once the corners are level, hose in the remaining perimeter of the pool.

You can lift the pool using a lever such as steel bar. It is important however to make sure you place a slab of wood between the steel bar and the pool coping. (See diagram below).

An atmosphere line needs to be installed at this stage. The atmosphere line is usually 4" Agg line in geotextile stocking. It is installed at the deep end of the pool and allows you to monitor ground water at any stage. The pipe is left open to the atmosphere and a bathroom style grate may be used to dress when concreting is being done.

Once you are happy that the pool is level, you are ready to backfill around the pool with crusher dust, sand and cement. (The sand and cement mix should be approximately 8 parts sand and 1 part cement.)

For best results, keep the backfill and the water at the same level until finished. The pool should be checked for level every 15 minutes until it is about a—quarter full and continually there after until finished.

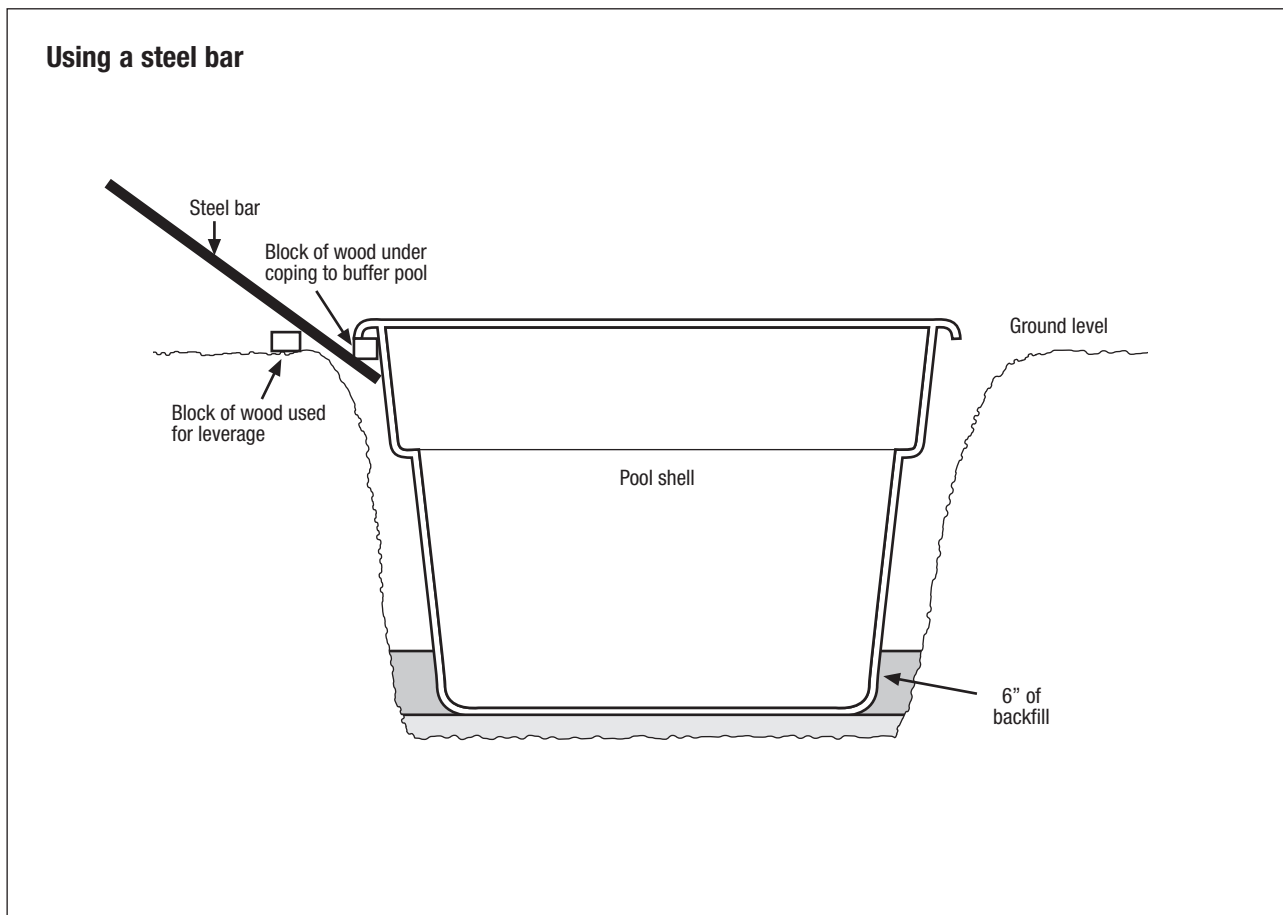

Drainage

Drainage is the important part of your installation for long term results. When installing your pool on a flat site, you are required to keep pool coping height a minimum of 8' above ground. When installing your pool on a sloped site, your pool coping must be a minimum of 6' above the highest point of ground. This is to ensure that ground water is not higher than pool water level.

If the water around the outside of the pool is higher than the water inside the pool it will be positively buoyant, therefore correct drainage is crucial. A stand pipe (*atmosphere line*) is to be installed as a matter of course with each installation.

The stand pipe is used to monitor ground water which

may exert excess hydrostatic pressure on the pool. On sloping sites additional subsoil drainage is required.

See diagrams below and refer to Australian standards for additional information.

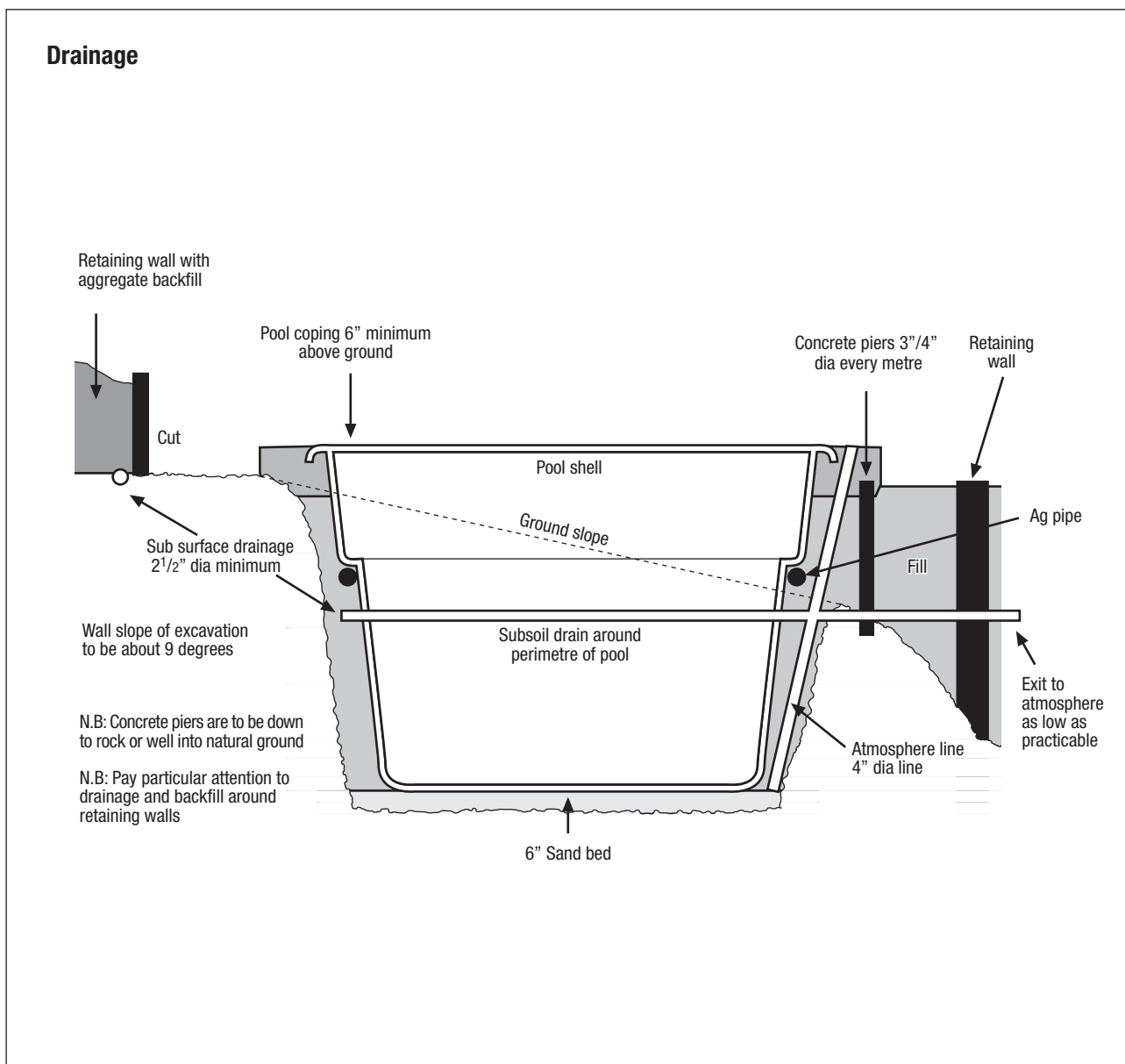

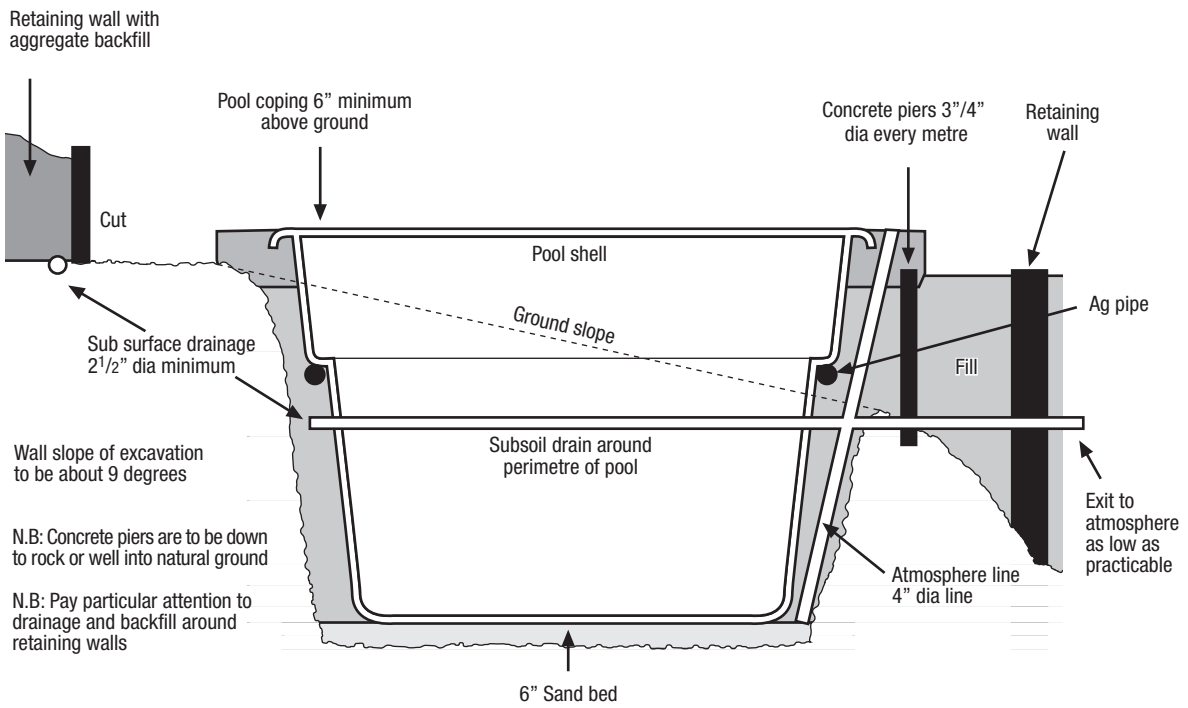
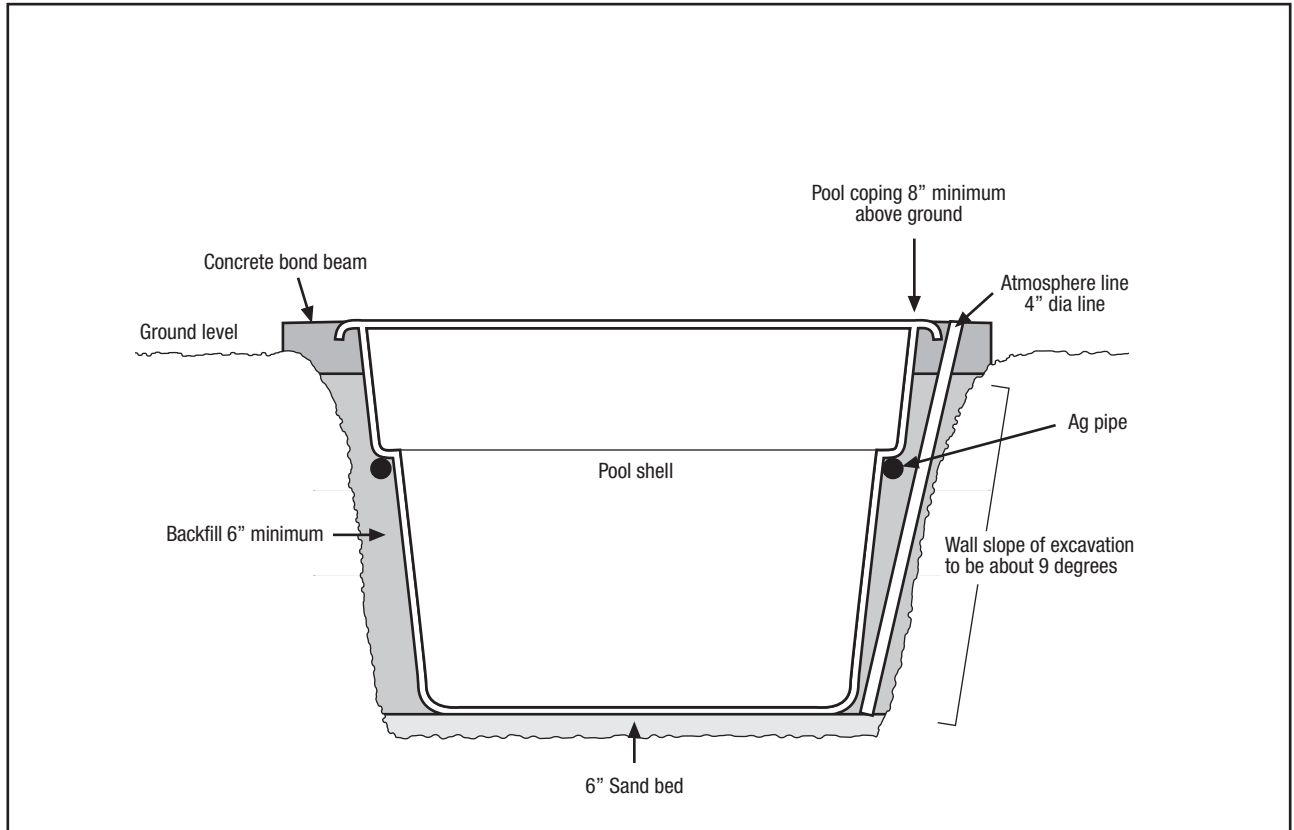

Plumbing

Once pool is level and backfilled, approximately level to the return jets you may start plumbing your pool suction and return lines (*keeping in mind where you are installing the filtration equipment*).

Be sure to test filtration equipment before burying pipes to check for leaks. Pipes should be backfilled using sand to eliminate any sharp objects coming in contract with pipes.

You will need to cut the skimmer box approximately 2 1/2" from the coping. Return eyeball will be needed to be cut 1'2" down from the coping taking care not to cut through the structural ribbing on the rear of the pool shell.

Plumbing schematic

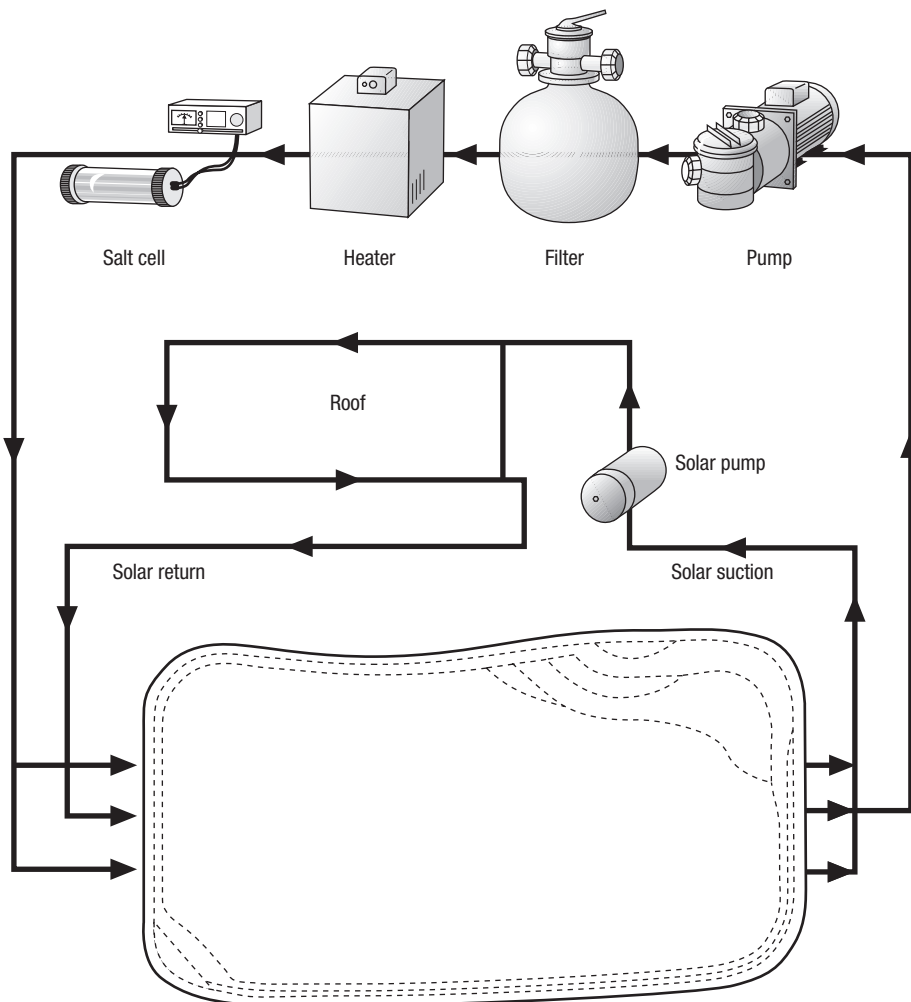

Filtration

HINTS FOR FILTRATION INSTALLATION

Position filtration within 26'3" of the skimmer box but at least 9'10" away from pool. Filtration level should be the same as coping level.

Use a 1 3/4" suction line for 1 h.p. Pumps and less. Use a 2" suction line for 1.25 h.p. Pumps and more. Ensure all pumps have space around them especially at the back for good air circulation.

No electricals should be within the splash zone which is described as 9'10" from pool water.

When connecting pipe, work use a colored priming solution to clean joins and colored glue to connect them. This is used so that you can see exactly which joins you have and haven't done.

It is best to install your filtration equipment on a stable base, usually precast concrete slab. You may need to prime the pump before starting. This is done by filling the pump basket with a couple of buckets of water then securing the lid.

For future use, you may install a waste line in your plumbing system. This is used to empty water from your pool and also to vacuum your pool to waste if it is excessively dirty. Install a three way valve after the filter. See diagram for assistance.

N.B.: When plumbing your filtration system, the salt cell must be plumbed last in line and after all other filtration equipment. This is so that super chlorinated water is not sent through any of the filtration equipment. Plumbing the salt cell last ensures that super chlorinated water is sent straight to the pool where it dilutes immediately.

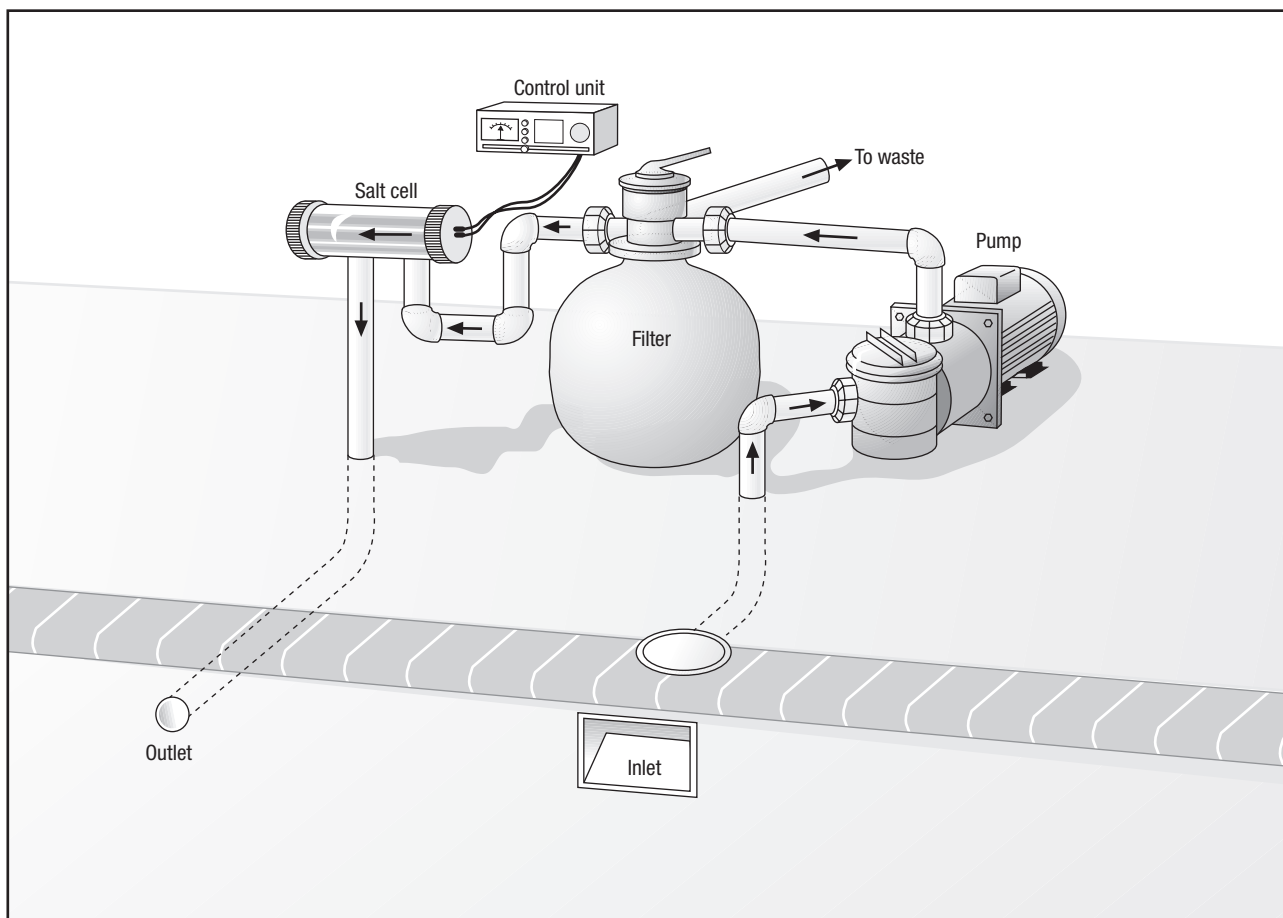

Filter set up

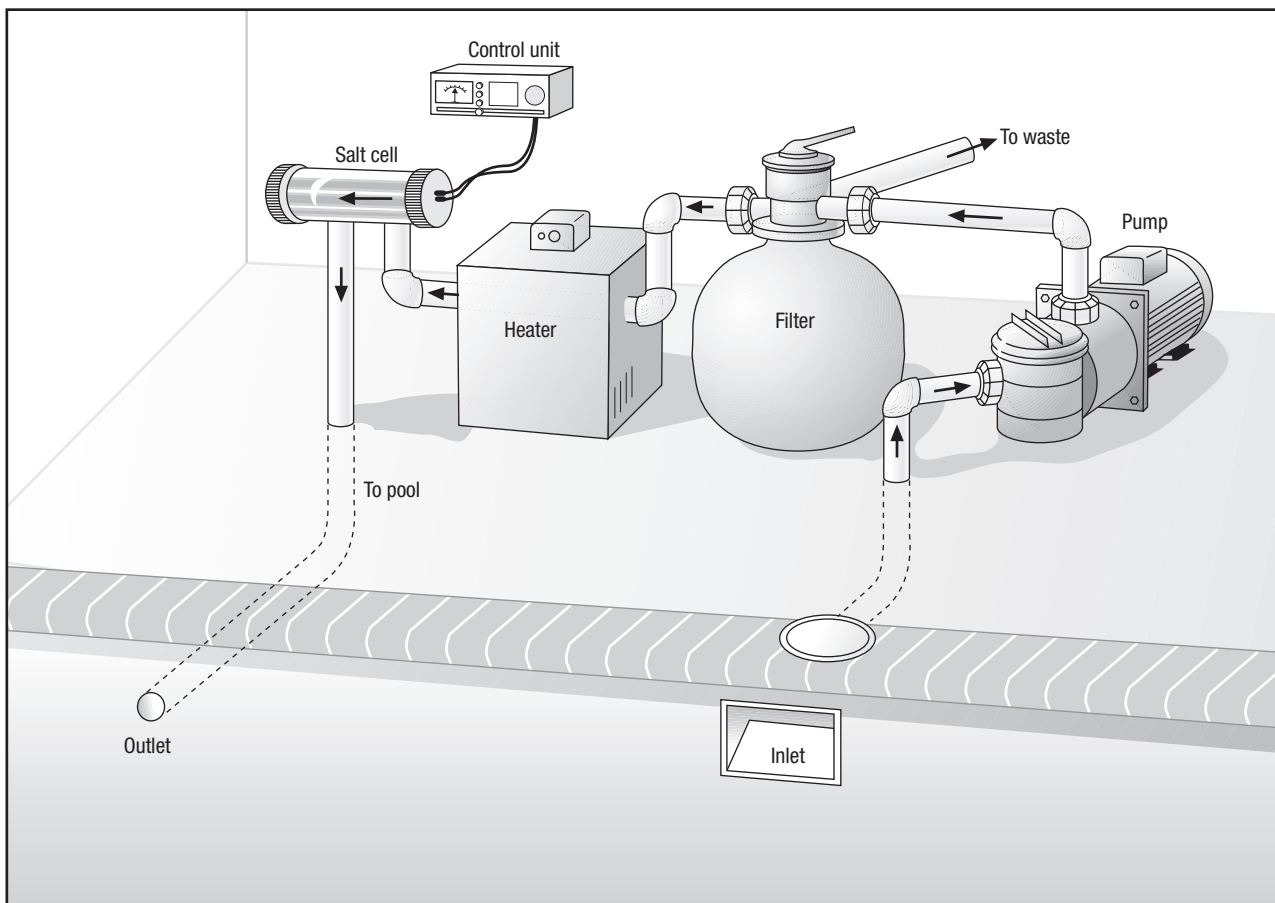
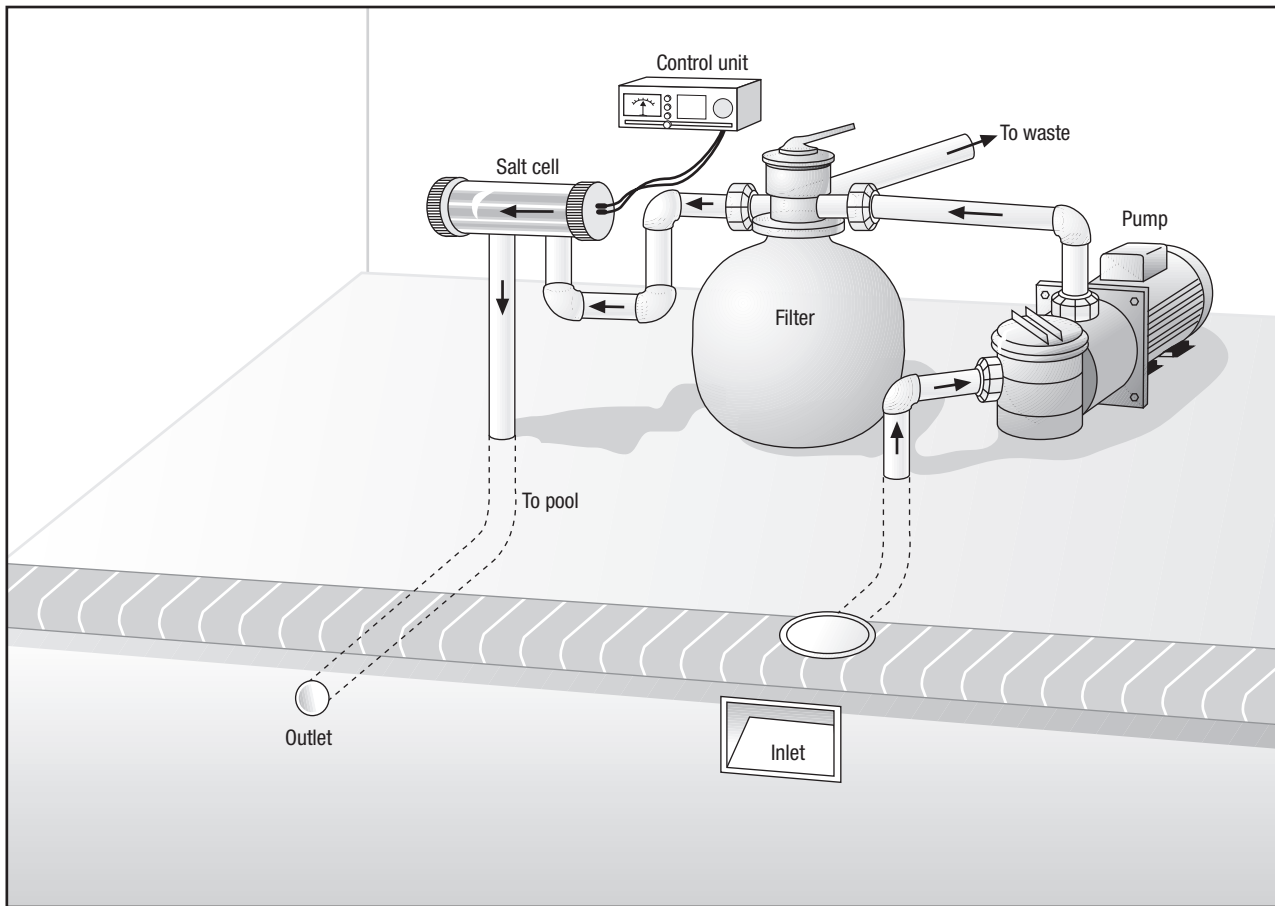

Venturi spa jets

A three-way valve must be used when installing spa jets as a separate return line is required. The three-way valve is installed after the salt cell and is used to control the flow to the jets and the flow to the pool.

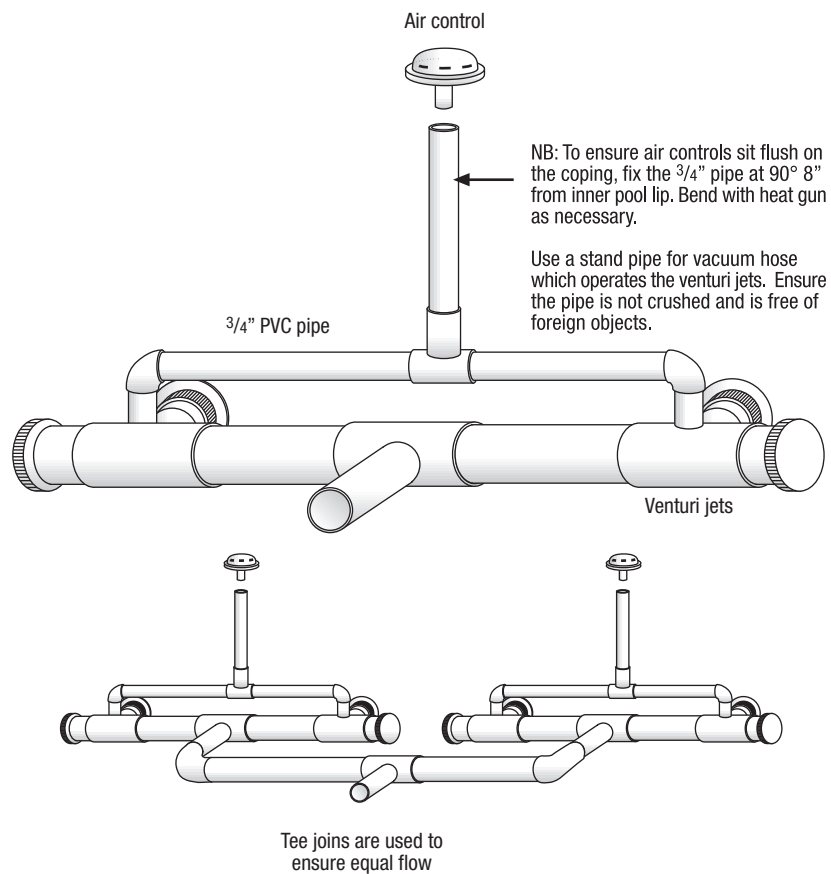

Skimmer box attachment

The skimmer box and return jets are factory fitted unless several pools are sent in transit at the same time. To allow the pool shells to stack attachments must be left off. Barrier Reef Pools will supply the Skimmer Box and return jets if factory fitting is not possible.

Using the escutcheon plate as a template, mark the position of the drill holes needed to mount the skimmer. Use the mounting screws supplied to connect the escutcheon plate to the skimmer box. Use silicone also to install the return jets (*do not use rubber washers*).

When installing the skimmer box V2 Z Bond Acetic Cure silicone is used to seal all bonding surfaces. Surfaces that need V2 Z Bond are; the front of the skimmer, the outside of the pool the inside of the pool and the rear of the escutcheon plate.

Another important note is that when plumbing suction line for pumps up to 1.25 H.P. 1³/₄" pipe may be used. However, for pumps 1.5 H.P. and larger 2" pipe must be used otherwise the pump may cavitate. Reducing bushes are included to allow both 1³/₄" & 2".

These calculations are based on a 26'3" head. Refer to your pump manufacturers specifications.

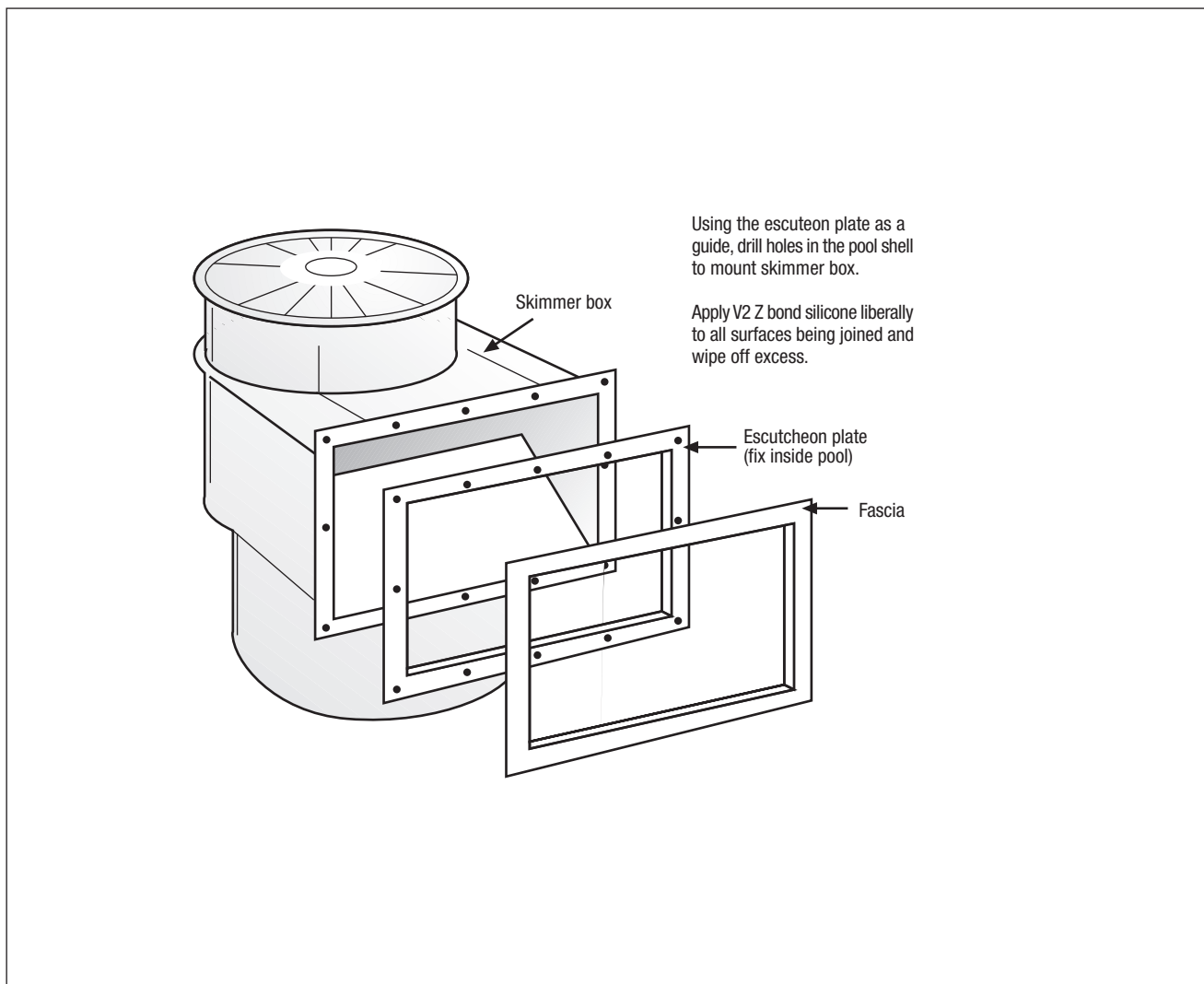

Concrete bond beam

Several finishes can be achieved and these are purely personal taste. However it is necessary to have a 1'4" concrete bond beam around the perimeter of the pool (refer to engineers detail and attached instructions). You may choose to pour your own concrete bond beam. If so refer to engineer's detail and read notes on following page. Pay particular attention to tucking concrete under the pool coping.

Make sure that if you are building retaining walls and landscaping above the level of the pool, it is correctly drained. If you do not drain around your pool sufficiently you will increase the water table around the pool which may cause problems in the future.

CONCRETE MUST BE TUCKED RIGHT UNDER THE FIBERGLASS COPING.

Please refer our ENGINEERS SPECIFICATIONS and you will see that concrete bond beam must be:

1. Reinforced with F52 mesh and S12 bars as per engineers detail.

2. Steel must be affixed to coping with wires-ties, which are attached to coping.

3. Concrete must be 4" thick, be level with coping top, slope away from pool by calculating ratio 1:80 ratio per Australian standards.

4. And, most IMPORTANT, Concrete must be forced right under fiberglass coping so there is no void under the coping.

5. RESULT - It is impossible for coping to move away from concrete AND it is impossible for any water to pass between concrete and coping.

REPEAT - CONCRETE MUST BE TUCKED RIGHT UNDER FIBERGLASS COPING AND MESH TIED TO THE SHELL.

variations from the design shape (see Figure 1):

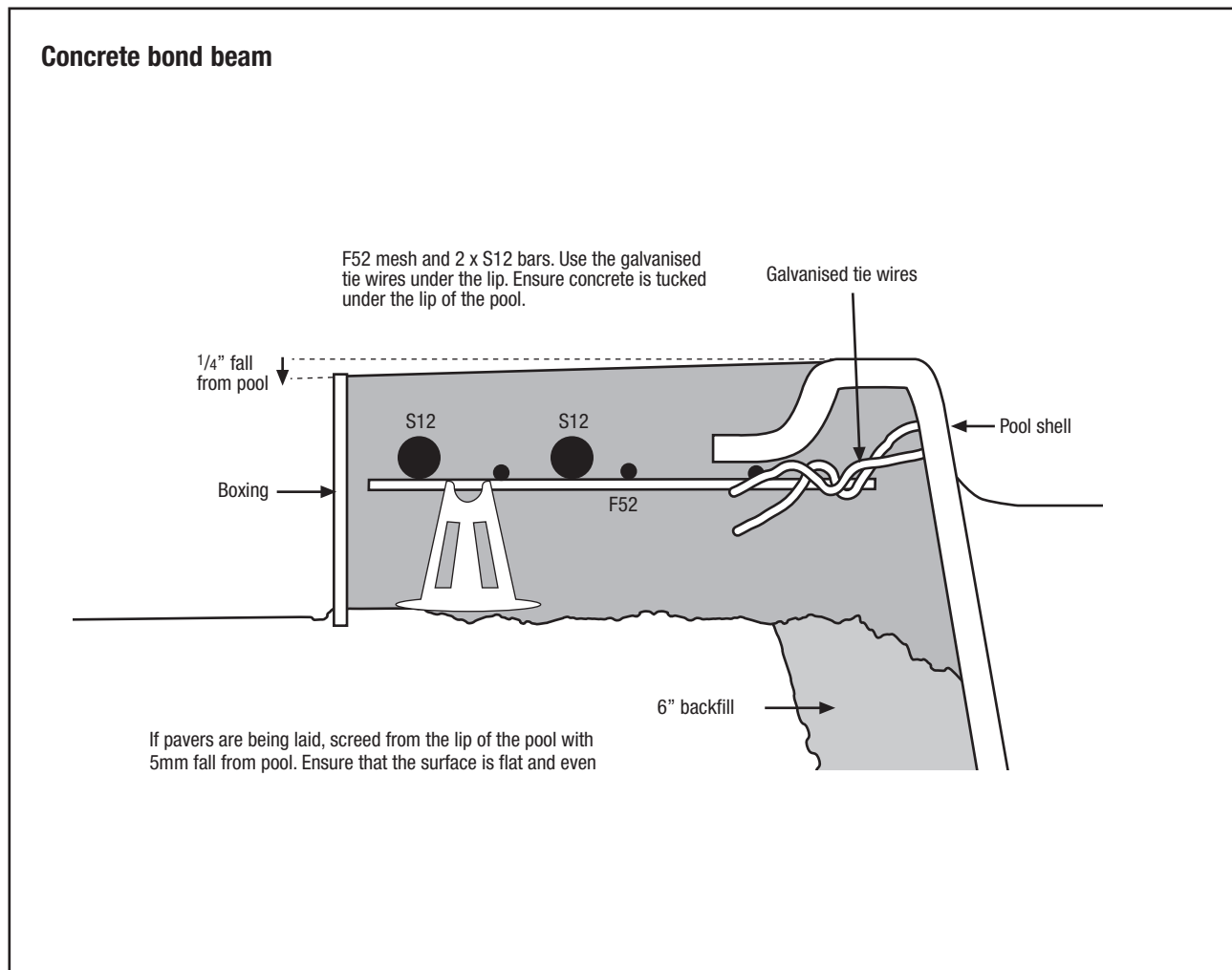

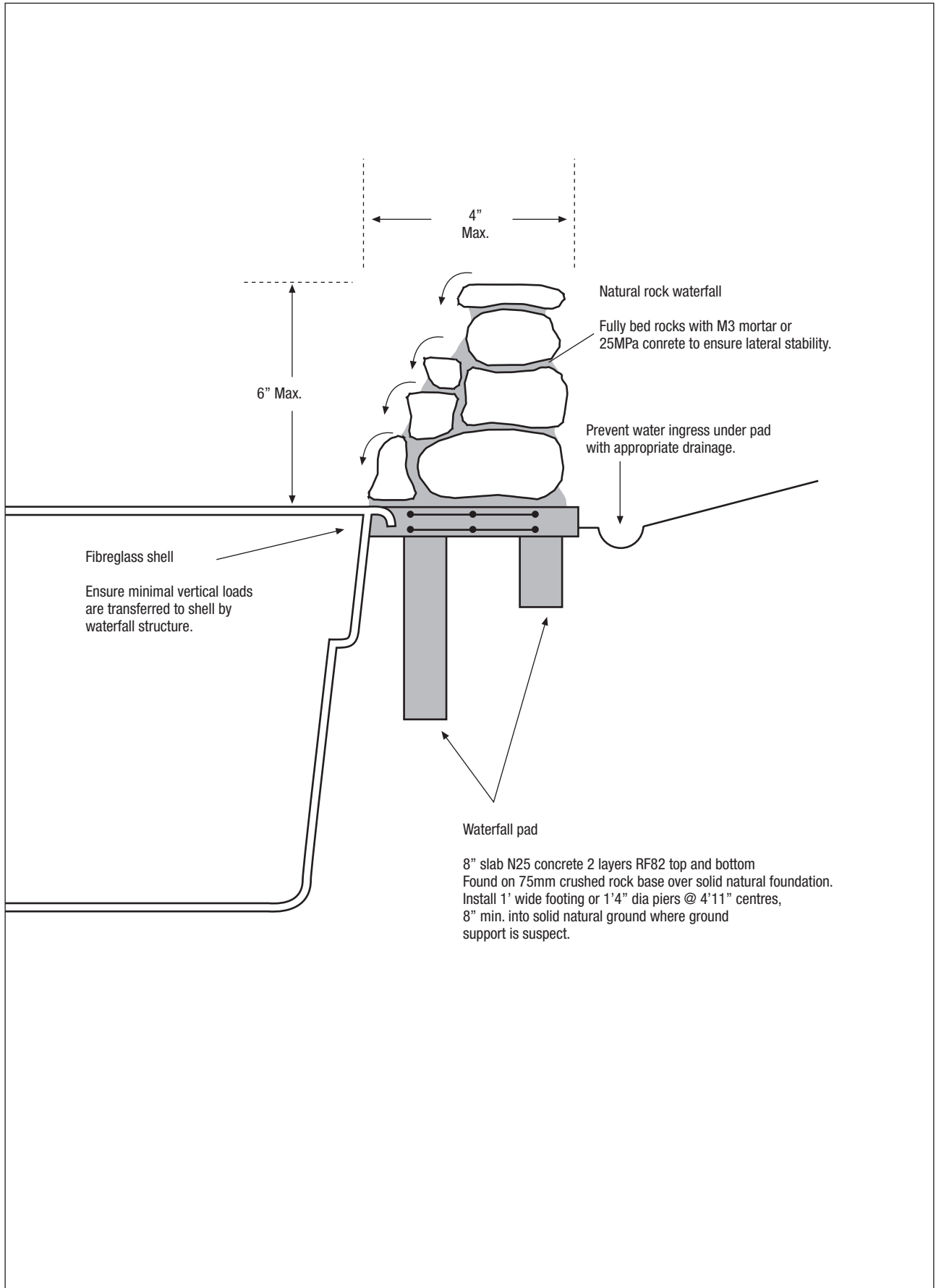

Light installation

Locate the pool light in an accessible location for future servicing. When installed correctly the front face of the pool light will project out from the wall by: 1" with

standard clear dissfuser, 1" with snap on blue or green lens, 1" with stainless steel ring

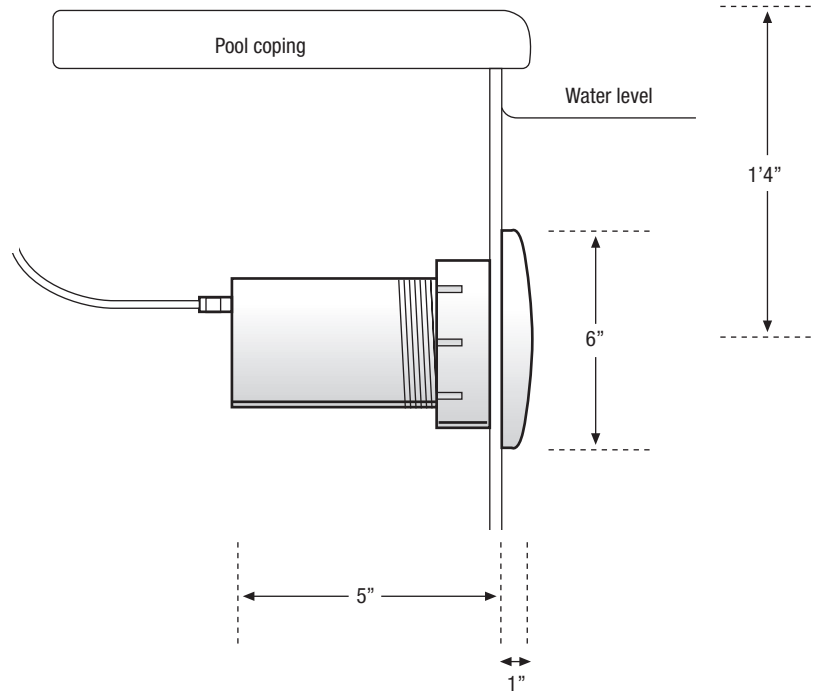

Light should be set 1' – 1'4" below the water level. The outlet for the conduit should be positioned so that Gland adaptor and attachment bracket can be positioned as shown in diagram (Use "Template for fibreglass pool installations" as provided to mark drill centres). Glass conduit to outside wall of pool before back filling.

Screw attachment bracket and gland adaptor to wall sealing with silicone sealant before back filling. Install light, wind coils of flex around clips to enable easy removal of light for servicing. The transformer needs to be installed in an accessible area to allow for servicing when required.

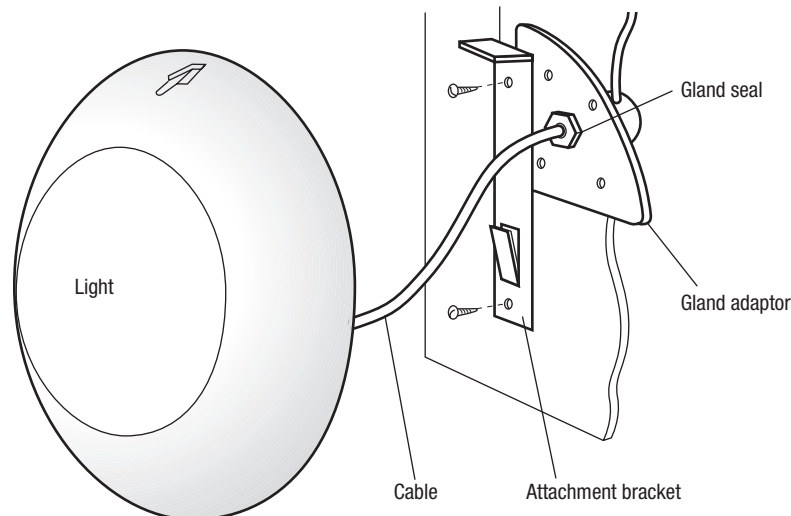

IMPORTANT INFORMATION IN RELATION TO YOUR BARRIER REEF POOL

This label indicates the serial number of the pool, the model type and color and whether it includes an air manifold. Also the ICC File number in relation to the ICBO approval. This swimming pool must never be emptied.

10125 10.1 BARRIER REEF

OCEAN

MANIFOLD ICC FILE # XX-XX-XX

DO NOT EMPTY SWIMMING POOL